



Electronic DC loads

MULTI-CHANNEL LOAD

PMLA SERIES

Electronic DC Loads

MULTI-CHANNEL LOAD PMLA SERIES



- Standard variant: up to 12 channels of 150 ... 600 W
- Low Power variant: up to 72 channels of 30 ... 120 W
- High Power variant: 1 channel of max. 2,100 W
- Channel expansion via slave devices
- Maximum 96 channels per system
- Systems with mixed variants
- Operation via graphical touch interface
- CC, CV, CR, CP mode
- Synchronization of load inputs
- Fast block data transfer
- Dynamic loads
- Group addressing and naming
- Discharge function for energy storage tests
- SCPI programming with measurement function
- MPP tracking
- Trigger model
- Internal measurement data memory
- Bilingual help system (DE/EN)

PMLA SERIES – Brief Profile

The PMLA multi-channel load combines up to 12 load channels/modules in a standard 2 U device and up to 72 channels in a low-power LP variant with 3 U. Another high-power HP variant offers a powerful channel with up to 2,100 W in a 2 U housing. A master device, which has both a graphical user interface and various data interfaces, controls all load channels of the system, which can be expanded as required by one or more slave devices. All variants can be combined: standard, LP, and HP. The load channels are galvanically isolated from each other, allowing multi-channel test systems to be implemented easily and safely.

The H&H SyncroLink interface ensures synchronous switching of the load inputs, even in systems with different H&H series devices.

Interfaces

Standard Master

- RS-232
- USB
- LAN
- GPIB
- CAN
- Analog
- System bus
- User interface

Standard Slave

- RS-232
- USB
- LAN
- GPIB
- CAN
- Analog
- System bus
- User interface

PMLA LP (Master)

- RS-232
- USB
- LAN
- GPIB
- CAN
- Analog
- System bus
- User interface

PMLA HP (Slave)

- RS-232
- USB
- LAN
- GPIB
- CAN
- Analog
- System bus
- User interface

Basic equipment Option not available

Applications

- Calibration of driver outputs (control units)
- Simulation of consumers in vehicle's electrical system
- Burn-in applications

Test objects

- Batteries and rechargeable batteries
- Cable harnesses
- Damping systems
- DC/DC converters
- Power control units
- Sensors
- Fuse boxes
- E-fuses
- Control units
- Zone controllers
- Power distributors
- Electronic assemblies

Configuration of Load Modules

The load inputs of all channels are galvanically isolated from each other.

Using definable channel groups and names, multiple modules can be combined into logical units that are then programmed simultaneously. For details, see [Application Note 14](#).

PMLA Standard

Master or slave

Depending on the composition, the standard PMLA multi-channel load has up to 3 cooling units, each with 4 mounting slots for load modules. Modules are available with power of 150 W, 300 W, 450 W, or 600 W. Depending on power, a module occupies one (150 W), two (300 W), three (450 W), or four (600 W) mounting slots. A module cannot be distributed across multiple cooler units.

The modules are available in four voltage classes (40 V, 60 V, 120 V, and 240 V) and for currents from 1 to 120 A. This allows various load combinations to be realized, such as:

1 x 600 W + 1 x 450 W + 2 x 300 W + 1 x 150 W. The total power is max. 1,800 W.

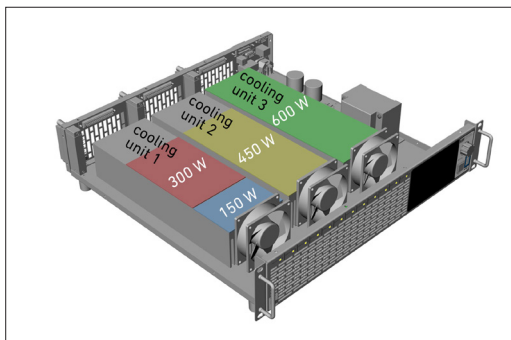

3 cooling units with 150 W, 300 W, 450 W, and 600 W module

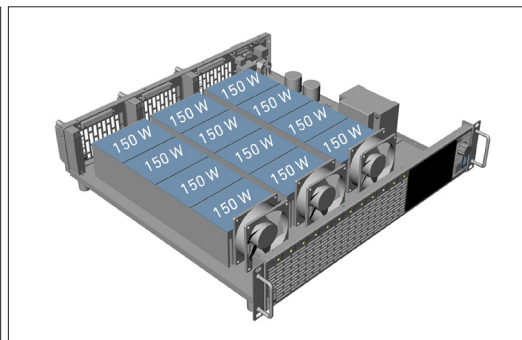

Example: 1 PMLA master device with 3 cooling units and 12 load channels with 150 W each

PMLA LP (low power)

Master

The PMLA LP variant also allows up to 3 cooling units to be integrated, but with 24 load module slots each. Modules are available with 30 W, 60 W, 90 W, or 120 W, with one slot occupied per 30 W. A module cannot be distributed across multiple cooling units.

The LP variant offers voltage classes of 10 V, 40 V, 60 V and 120 V and currents from 1 to 32 A. This means that a device with 3 U can accommodate up to 72 load channels.

The total power is max. 2,160 W per device. An LP device is always a master unit.

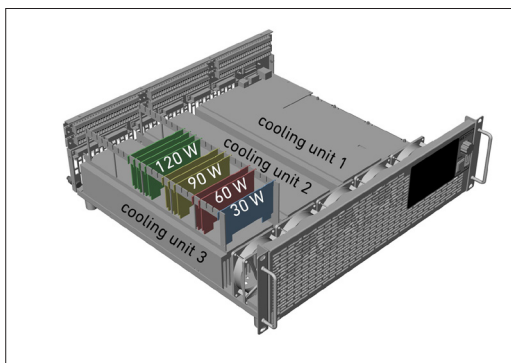

30 W, 60 W, 90 W, and 120 W module

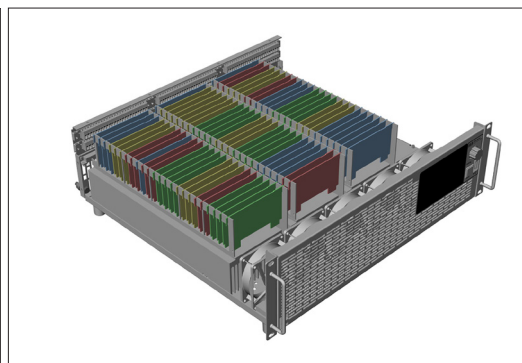

Example: 1 PMLA LP device with 3 cooling units, fully assembled with mixed load channels

PMLA HP (high power)

Slave

The PMLA HP variant serves as a powerful channel for system expansion with a PMLA Standard or LP master. One load channel with 1,400 W or 2,100 W is housed in a 2 U casing. Voltage classes 60 V, 120 V and 240 V with 16 to 180 A are available. The PMLA HP is always designed as a slave.

Features

Load and sense connections

The load inputs are provided on pluggable terminal strips for standard and LP versions. Matching mating connectors with coding pins are supplied with the terminal strips. All load inputs are galvanically isolated from each other.

On PMLA HP models, the load connections are designed as flat copper bars.

The sense connections are located on rear I/O ports (D-sub sockets) on standard and LP versions and on 2-pin strips on HP models.

I/O port

for PMLA Standard & HP

analog signals
in realtime

Standard I/O port with control and measurement signals for each channel:

- Analog load setting, in realtime for I and U, software-controlled for P and R
- Load input switching
- Analog voltage monitor output
- Analog current monitor output
- Sense inputs

Trigger model

In digital remote control mode, the trigger model ensures that all channel inputs are switched as synchronously as possible or that a programmed waveform is started for all selected channels.

H&H SyncroLink

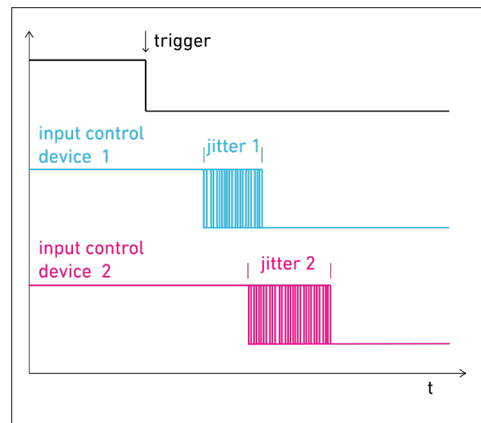

Jitter when repeatedly switching the load input on different series devices

Every device reacts with a certain amount of jitter, a variable delay between the control event and execution. This cannot be avoided, but additional delays between multiple H&H devices can be reduced using the H&H SyncroLink cable. It ensures synchronization via the RS-232 interfaces of all devices, even those from different series.

For details, see [Application Note 21](#).

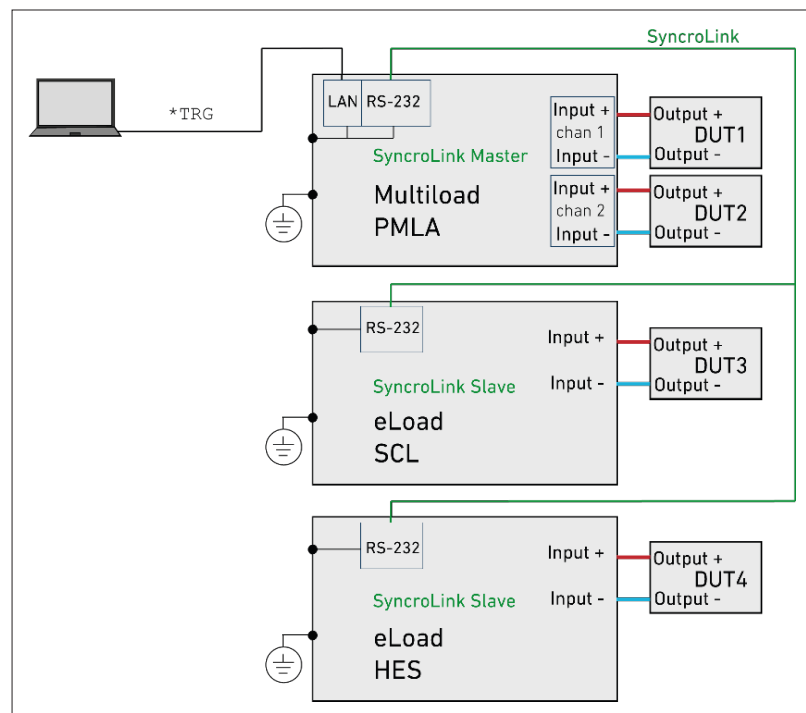

Interconnection via H&H SyncroLink

Protective devices, messages

- Current limitation
- Power limitation
- Overtemperature protection
- Overvoltage notification
- Reverse polarity indication
- Undervoltage protection

Cooling

The airflow from the front panel to the rear panel allows compact cabinet systems with many devices to be implemented without gaps.

Factory calibration certificate (FCC-PMLA)

free of charge

A free factory calibration certificate (FCC) is supplied with the devices. The calibration process is monitored in accordance with DIN EN ISO 9001. This calibration certificate documents traceability to national standards for the representation of physical units in accordance with the International System of Units (SI).

For use under laboratory conditions, H&H recommends a calibration interval of 2 years. This is an empirical value that can be used as a guideline for the initial period of use. The operator should adjust this interval accordingly depending on the intended use, duration of use, relevance of the application, and environmental conditions.

Drivers



Current NI-certified LabVIEW for download:
www.ni.com/downloads/instrument-drivers/

Functions

Operating modes

Each channel has the basic operating modes constant current, constant voltage, constant resistance, and constant power (CC, CV, CR, CP mode). In addition, a limit value for voltage or current can be specified in each operating mode. This results in the combined operating modes CC+CV, CP+CV, CR+CV, CP+CC, CR+CC, CV+CC.

In addition to the static operating modes, dynamic operation is possible with the LIST function or by MPP tracking.

Overcurrent and undervoltage limitation

Either an undervoltage or an overcurrent limitation can be activated and set. The active limit value is effective in all operating modes.

The undervoltage limitation works in two modes:

- regulating transition with slow control (e.g., battery discharge)
- switching transition with fast control (short dead time, e.g., when voltage is switched on)

Load profiles (LIST function)

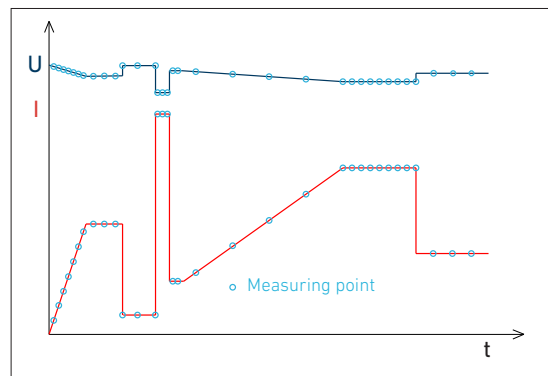

Waveform generated by the LIST function in CC mode with synchronized measurement of time, voltage, and current

Each channel can simulate load profiles in all operating modes CC, CV, CR, CP using the LIST function. Each setting point has a dwell time and a ramp time.

Voltage and current are measured synchronously and stored with a time stamp. Individual sampling times can be defined for each waveform section.

Measurement data acquisition (DAQ)

In digital remote control mode, all channels can independently and synchronously store voltage and current with time stamps at variable intervals. When the data memory is full, recording can either be stopped or the old data can be overwritten according to the ring buffer principle.

Binary block data transfer

Data transfer according to the IEEE 488.2 standard allows the transfer of measurement data in a defined binary block format. This method ensures more efficient and faster reading of large amounts of data compared to the transfer of ASCII data. Binary block data transfer is available exclusively for reading measurement data points and only possible via RS-232, USB, or LAN.

MPP tracking

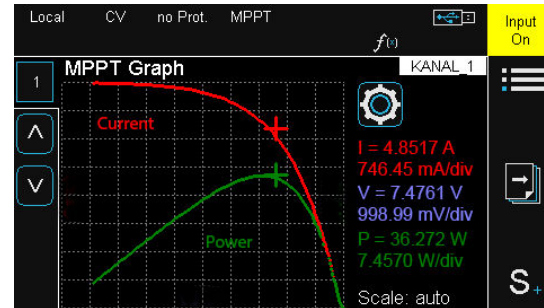

The Maximum Power Point Tracking (MPPT) function consists of two sub-functions, sweeping and tracking, which alternate continuously at a configurable interval. If the measured open-circuit voltage at start-up is higher than the minimum voltage, the electronic load performs a sweep and then adjusts the global MPP found during the sweep.

U/I and U/P characteristic curve on the user interface

The swept U/I characteristic curve is displayed together with the U/P characteristic curve in the function graph of the user interface. The previously found MPP is marked with a '+'. The U/I characteristic curve can be read out via a data interface.

Discharge function, energy storage test

The discharge function tests energy storage devices such as batteries, rechargeable batteries, ultra-caps, electrolytic capacitors, etc., by discharging them in CC, CP, or CR mode. The discharge function can be combined with the list function to enable pulsed discharge.

A very helpful function is IUa discharge (CC+CV discharge): the test object is discharged with a constant current up to a defined voltage. This voltage is then kept constant until a defined minimum current is reached.

Stop criteria are charge, energy, time, current, and voltage.

Watchdog function

To protect the test object in the event of communication problems, each channel in digital remote control mode has a watchdog function that switches off the load input if the previously programmed watchdog delay time expires without the watchdog being reset.

Control speed switching

For certain test objects or very long connection cables, it may be necessary to adjust the control time constant of the electronic load in order to achieve stable operation. The control speed can be switched for this purpose.

Save settings

On request, the settings of all channels can be saved in one of 10 memory locations so that they can be reloaded at a later time. Each channel saves its own settings.

This means that entire systems can be reconfigured at the touch of a button.

Each channel can be configured to be set to reset state or to one of the memory positions 0 ... 9 when powered up.

Setting menu

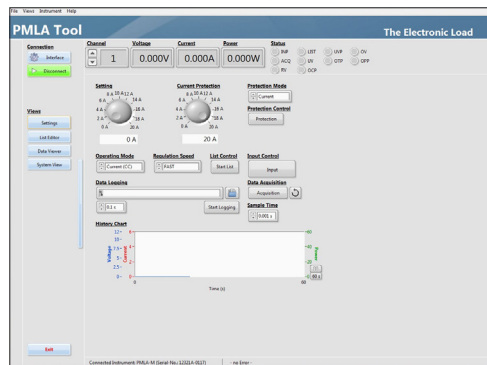

The PMLA tool is control software for up to 72 channels of electronic multi-channel loads from the PMLA series. A navigation bar switches between the individual applications. The main menu (Settings) is used to configure the most important device settings and select the channel to be controlled. A measured value and status bar provides information about the current device status. The user can configure and activate the data logging function.

Download: www.hoecherl-hackl.de/downloads/

Data viewer

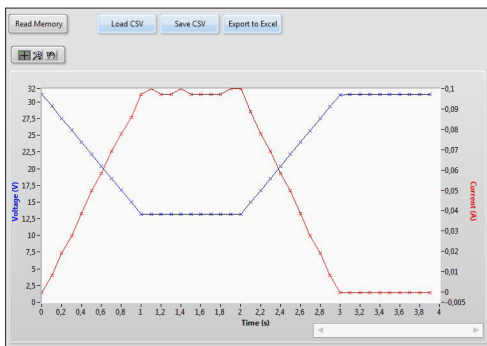

Measurement values from the device's own DAQ memory are read from the device using the Data Viewer and displayed graphically. The data can be saved to a data carrier as a CSV file for further processing. Individual measurement points (time stamp, voltage, current) are displayed as tooltips.

System view

Chan.	Go to Chan.	Go to Chan.	Go to Chan.	Go to Chan.	
1	0.005V	0.000A	19	0.002V	0.000A
2	0.011V	0.000A	20	0.009V	0.000A
3	0.006V	0.000A	21	0.010V	0.000A
4	0.009V	0.000A	22	0.007V	0.000A
5	0.019V	0.000A	23	0.011V	0.000A
6	0.014V	0.000A	24	0.019V	0.000A
7	0.009V	0.000A	25	0.009V	0.000A
8	0.012V	0.000A	26	0.004V	0.000A
9	0.005V	0.000A	27	0.007V	0.000A
10	0.011V	0.000A	28	0.007V	0.000A
11	0.019V	0.000A	29	0.005V	0.000A
12	0.008V	0.000A	30	0.010V	0.000A
13	0.008V	0.000A	31	0.005V	0.000A
14	0.012V	0.000A	32	0.004V	0.000A
15	0.008V	0.000A	33	0.004V	0.000A
16	0.012V	0.000A	34	0.006V	0.000A
17	0.011V	0.000A	35	0.004V	0.000A
18	0.019V	0.000A	36	0.005V	0.000A
			37	0.009V	0.000A
			38	0.012V	0.000A
			39	0.011V	0.000A
			40	0.003V	0.000A
			41	0.013V	0.000A
			42	0.007V	0.000A
			43	0.004V	0.000A
			44	0.003V	0.000A
			45	0.016V	0.000A
			46	0.007V	0.000A
			47	0.009V	0.000A
			48	0.009V	0.000A
			49	0.005V	0.000A
			50	0.009V	0.000A
			51	0.008V	0.000A
			52	0.007V	0.000A
			53	0.011V	0.000A
			54	0.007V	0.000A
			55	0.003V	0.000A
			56	0.010V	0.000A
			57	0.005V	0.000A
			58	0.004V	0.000A
			59	0.006V	0.000A
			60	0.002V	0.000A
			61	0.009V	0.000A
			62	0.009V	0.000A
			63	0.010V	0.000A
			64	0.012V	0.000A
			65	0.014V	0.000A
			66	0.010V	0.000A
			67	0.010V	0.000A
			68	0.009V	0.000A
			69	0.007V	0.000A
			70	0.005V	0.000A
			71	0.012V	0.000A
			72	0.011V	0.000A

The "System View" displays the most important statuses as well as the voltage and current of the channels available in the system. By quickly selecting a channel, the new channel is selected and immediately switched to the Settings view.

PMLA Standard Master Front

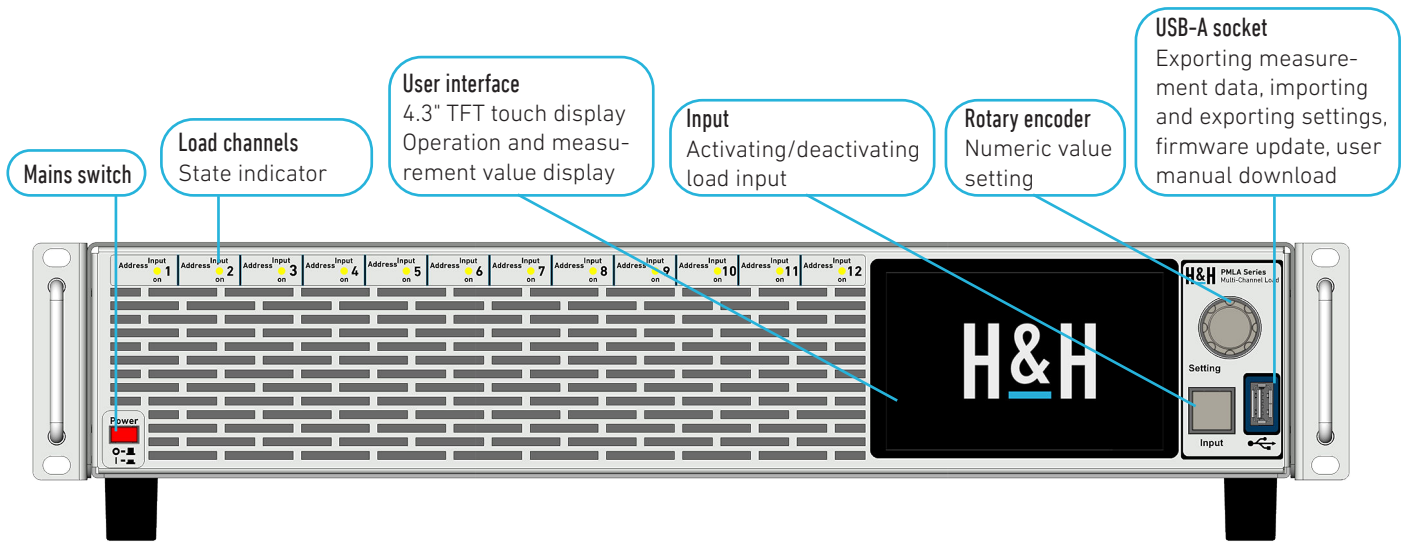

PMLA Standard Master Rear

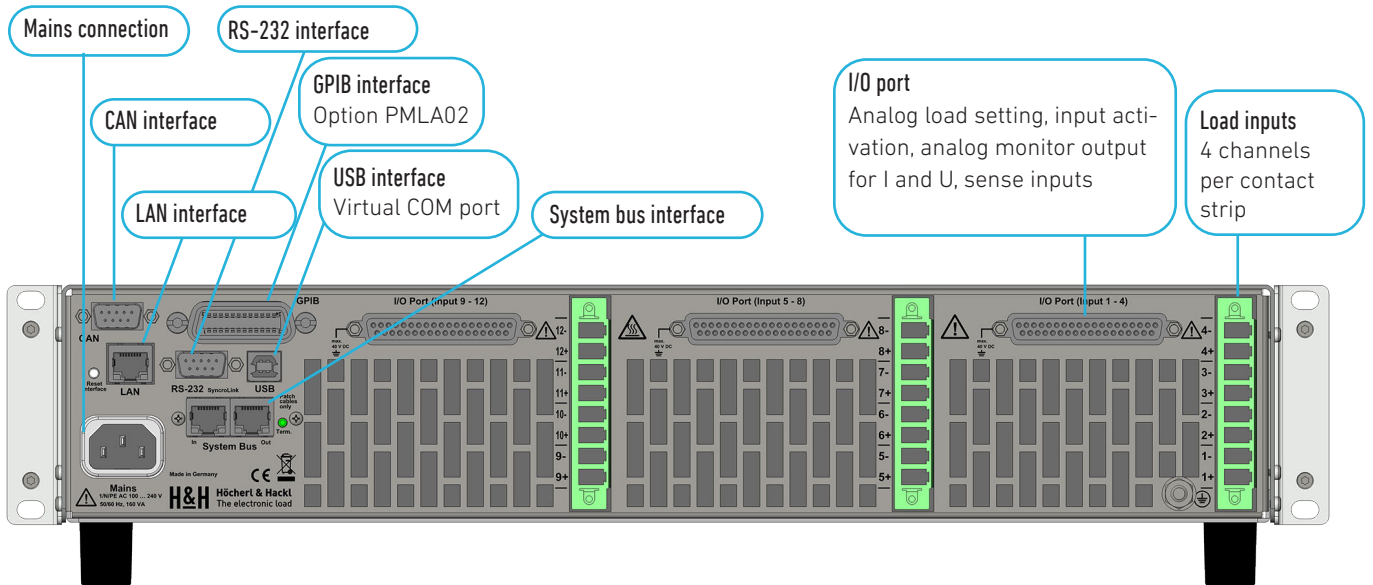

PMLA Standard Slave Front

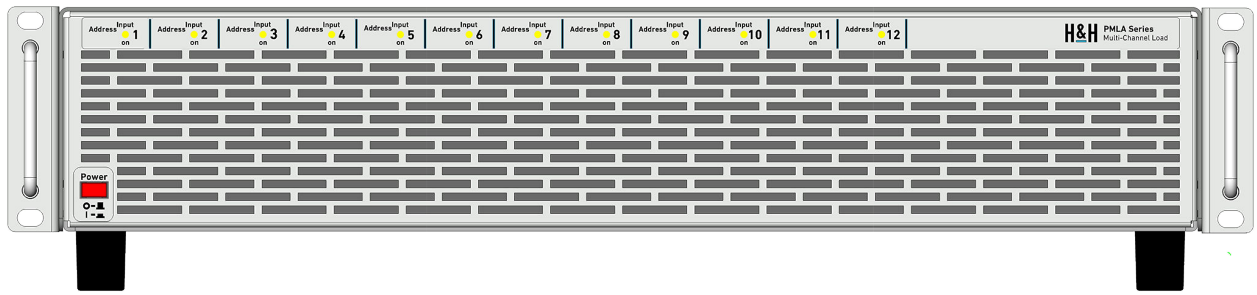

PMLA Standard Slave Rear

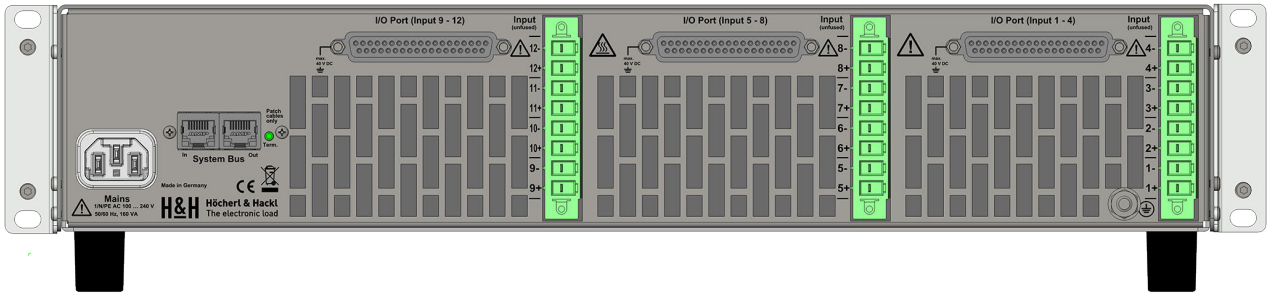

PMLA LP Front

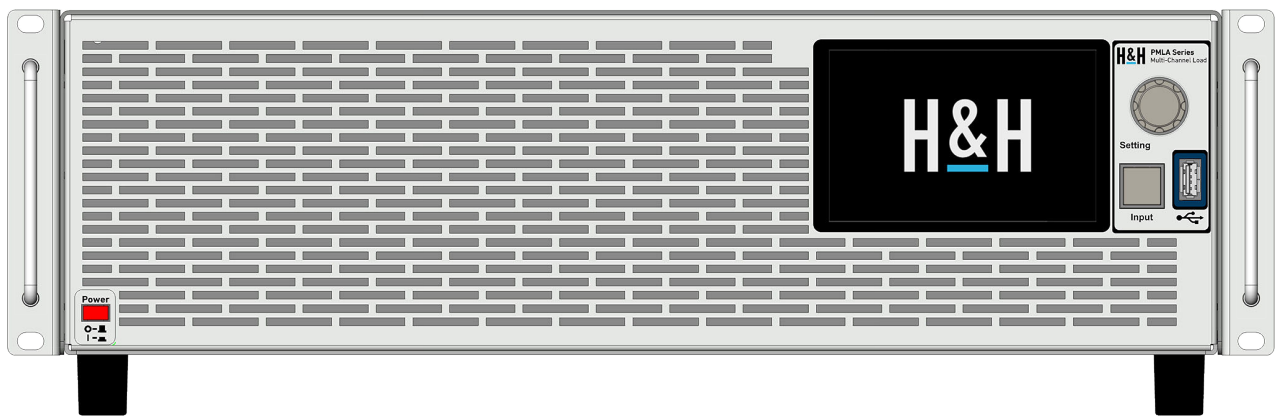

PMLA LP Rear

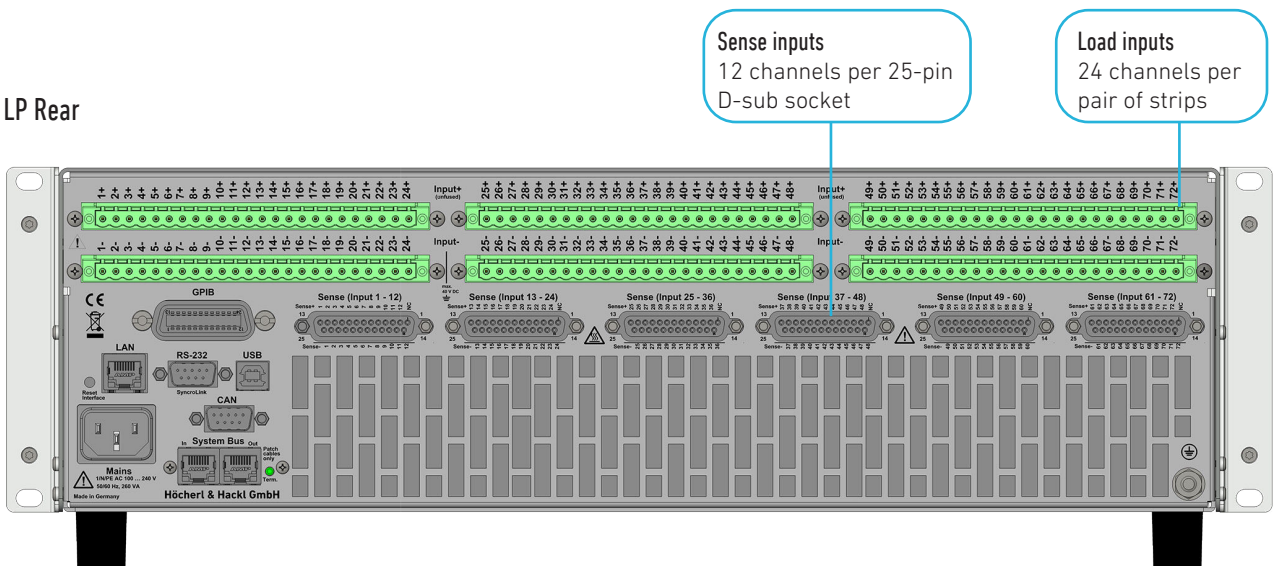

Sense inputs
12 channels per 25-pin
D-sub socket

Load inputs
24 channels per
pair of strips

PMLA HP Front

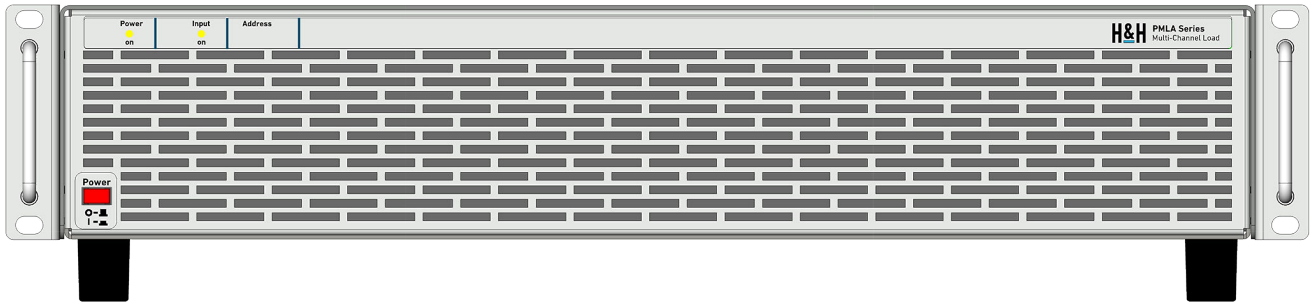

PMLA HP Rear

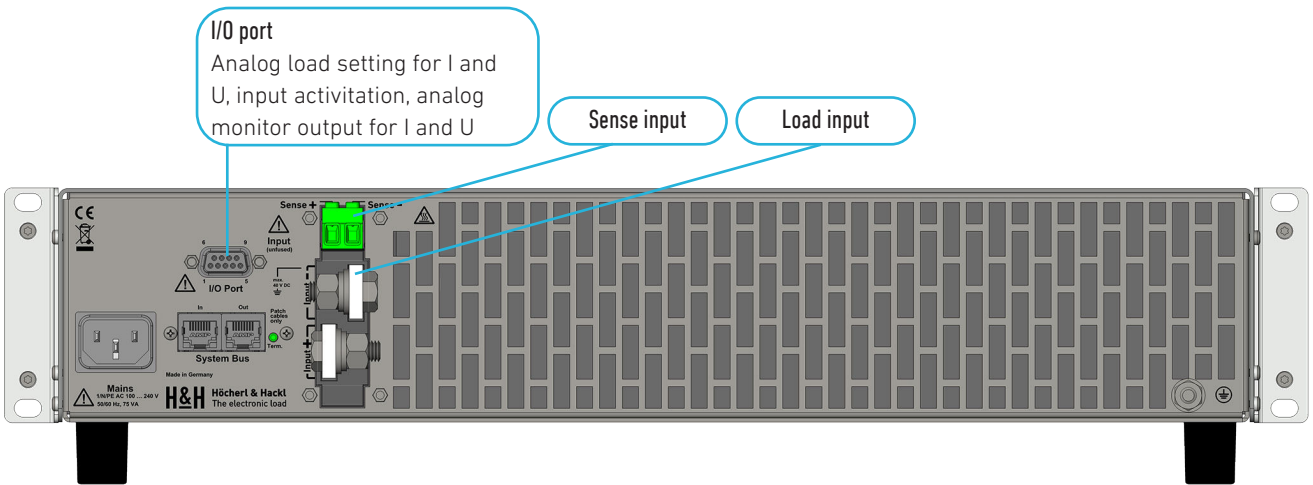

Permissible voltages

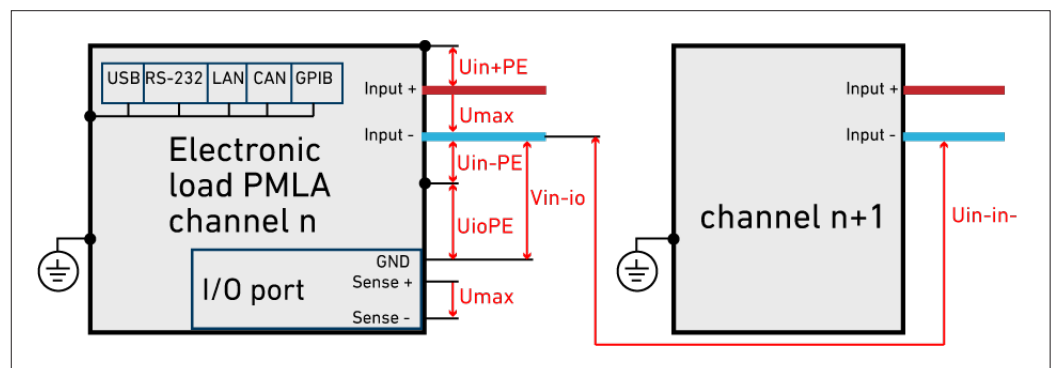

Permissible voltages at input and sense of a channel and between channels.
For specifications, see series-specific data.

Module Overview PMLA Standard

Series D, Rev. 1. Subject to technical changes.

Module	Maximum Input Voltage U_{max}	Maximum Current I_{max}	Maximum Continuous Power P_{max}
MA15-04C30	40 V	30 A	150 W
MA15-06C20	60 V	20 A	150 W
MA15-06C5	60 V	5 A	150 W
MA15-12C10	120 V	10 A	150 W
MA15-12C2	120 V	2 A	150 W
MA15-24C1	240 V	1 A	150 W
MA15-24C5	240 V	5 A	150 W
MA30-04C60	40 V	60 A	300 W
MA30-06C10	60 V	10 A	300 W
MA30-06C40	60 V	40 A	300 W
MA30-12C20	120 V	20 A	300 W
MA30-12C4	120 V	4 A	300 W
MA30-24C10	240 V	10 A	300 W
MA30-24C2	240 V	2 A	300 W
MA45-04C90	40 V	90 A	450 W
MA45-06C15	60 V	15 A	450 W
MA45-06C60	60 V	60 A	450 W
MA45-12C30	120 V	30 A	450 W
MA45-12C6	120 V	6 A	450 W
MA45-24C15	240 V	15 A	450 W
MA45-24C3	240 V	3 A	450 W
MA60-04C120	40 V	120 A	600 W
MA60-06C20	60 V	20 A	600 W
MA60-06C80	60 V	80 A	600 W
MA60-12C40	120 V	40 A	600 W
MA60-12C8	120 V	8 A	600 W
MA60-24C20	240 V	20 A	600 W
MA60-24C4	240 V	4 A	600 W

Module Overview PMLA LP Variant

Series D, Rev. 1. Subject to technical changes.

Module	Maximum Input Voltage U_{max}	Maximum Current I_{max}	Maximum Continuous Power P_{max}
MALP03-01C1	10 V	1 A	10 W
MALP03-01C2	10 V	2 A	20 W
MALP03-01C4	10 V	4 A	30 W
MALP03-01C8	10 V	8 A	30 W
MALP03-04C0.1	40 V	0.1 A	4 W
MALP03-04C0.5	40 V	0.5 A	20 W
MALP03-04C1	40 V	1 A	30 W
MALP03-04C2	40 V	2 A	30 W
MALP03-04C4	40 V	4 A	30 W
MALP03-04C8	40 V	8 A	30 W
MALP03-06C2	60 V	2 A	30 W
MALP03-12C1	120 V	1 A	30 W
MALP06-01C16	10 V	16 A	60 W
MALP06-01C8	10 V	8 A	60 W
MALP06-04C16	40 V	16 A	60 W
MALP06-04C2	40 V	2 A	60 W
MALP06-04C4	40 V	4 A	60 W
MALP06-04C8	40 V	8 A	60 W
MALP06-06C4	60 V	4 A	60 W
MALP06-12C2	120 V	2 A	60 W
MALP09-01C12	10 V	12 A	90 W
MALP09-01C24	10 V	24 A	90 W
MALP09-04C12	40 V	12 A	90 W
MALP09-04C24	40 V	24 A	90 W
MALP09-04C3	40 V	3 A	90 W
MALP09-04C6	40 V	6 A	90 W
MALP09-06C6	60 V	6 A	90 W
MALP09-12C3	120 V	3 A	90 W
MALP12-01C16	10 V	16 A	120 W
MALP12-01C32	10 V	32 A	120 W
MALP12-04C16	40 V	16 A	120 W
MALP12-04C32	40 V	32 A	120 W
MALP12-04C4	40 V	4 A	120 W
MALP12-04C8	40 V	8 A	120 W
MALP12-06C8	60 V	8 A	120 W
MALP12-12C4	120 V	4 A	120 W

Do you need modules with customized, perhaps particularly small current ranges?
Just ask us!

Module Overview PMLA HP Variant

Series D, Rev. 1. Subject to technical changes.

Module	Maximum Input Voltage U_{max}	Maximum Current I_{max}	Maximum Continuous Power P_{max}
MAHP140-06C120	60 V	120 A	1400 W
MAHP140-12C60	120 V	60 A	1400 W
MAHP140-24C32	240 V	32 A	1400 W
MAHP210-06C180	60 V	180 A	2100 W
MAHP210-12C90	120 V	90 A	2100 W
MAHP210-24C48	240 V	48 A	2100 W

Options and Accessories

Item	Description
PMLA02	GPIB interface (option for PMLA Standard Master and LP)
PH8/7.62-BU43	additional mating connector for a cooling unit (standard)
PH24/5.08-BU12	additional mating connector for a cooling unit (LP)
	additional mating connector for sense terminals (HP)
CP-PC RD	additional coding pins for load input contact strip and mating connector (standard)
CP-MSTB	additional coding pins for load input contact strip and mating connector (LP)
FCC-PMLA/CH	factory calibration certificate for 1 load module
K-RS-SNM 9-9	RS-232 cable (null modem cable) PMLA series
SX	modified setting range for PMLA series, only after consultation with H&H
SSX	customized setting range, only after consultation with H&H
Patch cable	patch cable 1:1 blue

Series-Specific Data PMLA Standard

Series D, Rev. 1. Subject to technical changes.

The specified accuracies apply at an ambient temperature of 23 ± 5 °C with connected sense lines and when the devices are used with clean voltages (ripple and noise < 0.1 %). Accuracy may worsen at voltages with higher interference values. Technical data may vary for special devices/modules.
 Permissible voltages are positive or negative DC voltages.

Channels and functions	
Number of channels per device	max. 12
Number of channels per system	max. 96
Total power per device	max. 1800 W
Functions	group addressing and name assignment overcurrent protection undervoltage protection dynamic loads with list function internal measurement data memory discharge function for energy storage tests SCPI programming with measurement function MPP tracking trigger model SyncroLink for trigger synchronization saving and loading device settings watchdog in remote control mode external control and monitor signals via I/O port
Operating modes	
Basic operating modes	CC, CV, CR, CP
Combined operating modes	CC+CV, CP+CV, CR+CV, CP+CC, CR+CC, CV+CC
Setting ranges	module-dependent
User interface	master: 4.3" TFT touch display slave: none
Current rise and fall times	
With fast regulation	module-dependent
With slow regulation	ca. 1 ms
Accuracy of setting values	
Voltage	± 0.1 % of setting, ± 0.1 % of range
Current	module-dependent
Resistance	module-dependent
Power	module-dependent
Resolution	12 bits
Accuracy of adjustable protective devices	
Overcurrent limitation	module-dependent
Undervoltage protection	± 0.2 % of setting ± 0.2 % of range
Resolution	12 bits
Accuracy of measurement	
Voltage	± 0.1 % of measured value ± 0.05 % of range
Current	module-dependent
Resistance	calculated from voltage and current values
Power	calculated from voltage and current values
Resolution	16 bits
Sampling time	100 μ s, not triggerable

Display accuracy	
Number of decimal digits	5
Accuracy	Accuracy of the respective measurement ± 1 digit of the display value
Dynamic function (LIST)	
Operating modes	CC, CV, CR, CP
Number of load levels	max. 100, with associated ramp and dwell time
Accuracy of load levels	see accuracy of setting
Pulse duration	0.2 ms ... 1000 s
Ramp duration	0 ... 1000 s
Resolution	0.2 ms
Accuracy of setting times	± 0.02 %
SyncroLink	
Synchronism between load channels (jitter) of the same system	max. 100 μ s
Synchronism between load channels (jitter) to further systems	max. 250 μ s
Measurement data acquisition (DAQ) to internal memory	
Accuracy	see accuracy of measurement
Resolution	16 bits
Sampling time	0.2 ms ... 1000 s, resolution 0.2 ms
Measurement data	timestamp, voltage, current
Number of measuring points	max. 500
Settings memory	
Number of memory positions (incl. programmed list)	10, selectable
I/O port: inputs and outputs	
Inputs	Activation state of load inputs sense inputs for all channels analog control signal 0 ... 10 V
Digital input levels	3 ... 30 V
Input resistance of analog inputs	> 10 k Ω
Outputs	Analog monitor outputs 0 ... 10 V for I and U
I/O port: accuracy of analog control 0 ... 10 V	
Voltage	± 0.2 % of setting, ± 0.1 % of range
Strom	module-dependent
I/O port: accuracy of analog monitor signals 0 ... 10 V	
Voltage	± 0.1 % of analog measurement signal, ± 15 mV offset
Current	module-dependent
Load capability	min. 2 k Ω

I/O port: permissible voltages	
Vin-io (GND - neg. load input)	max. 2 V
VioPE (GND - PE)	max. 40 V DC
Input	
Input resistance	> 50 kΩ with load input switched off, diode function with reverse polarity up to rated current
Input capacity	module-dependent
Parallel operation	up to 5 channels in analog master-slave mode (hardware-controlled)
Maximum input voltage U _{max}	module-dependent
Minimum input voltage U _{min}	module-dependent
Input: permissible voltages	
U _{in-PE} (neg. load input - PE)	max. ±40 V DC
U _{in+PE} (pos. load input - PE)	U _{max} + 40 V DC
U _{in-in-} (neg. load inputs between the channels)	max. ±40 V DC
Power	
Continuous power	module-dependent
Derating	-1.2 %/°C for T _a > 21 °C
Protection and monitoring	
Protective devices	overcurrent, overpower, overtemperature
Monitoring messages	overvoltage indicator, polarity reversal indicator, undervoltage indicator (if input voltage is too low for set load)
Connections	
Load input	Phoenix Contact PC5/8-STF1-7,62
Sense	37-pin D-sub female connector
Operating conditions	
Operating temperature	5 ... 40 °C
Storage temperature	-25 ... 65 °C
Max. operating height	2000 m above sea level
Pollution degree	2
Overvoltage category of mains	II
Max. Humidity	80 % at 31 °C, decreasing linearly to 50 % at 40 °C
Min. distance rear panel to wall or other objects	70 cm
Cooling	multi-stage air cooling, temperature-controlled, air inlet via the front panel, air outlet via the rear panel, suitable for gapless 19" mounting
Noise	max. 69 dB(A) at distance of 1 m
Mains voltage	1/N/PE AC 100 ... 240 V 50/60 Hz
Mains cable	length max. 3 m, cross-section of mains connection wires min. 1 mm ²
Power consumption	max. 160 VA

Mechanics	
Housing	19", 2 U
Dimensions W x H x D	485 x 109 x 485 mm
Installation depth	470 mm
Installation depth	89 mm
Weight	max. 18.3 kg
Color front panel	RAL7035 (light grey)
Color rear panel	stainless steel
Color cover	RAL7037 (stone grey)
Safety and EMC	
Protection class	1
Measurement category	0
Electrical safety	DIN EN 61010-1 DIN EN 61010-2-30
EMC, CE marking	DIN EN 61326-1 DIN EN 55011 DIN EN 61000-3-2 DIN EN 61000-3-3
Calibration	
Recommended calibration interval	2 years (empirical value as a guideline for the first period of use, can be adjusted depending on the intended use, duration of use, environmental conditions, relevance of the application)
FCC-PMLAxx	factory calibration certificate
Warranty	
Warranty	2 years

Series-Specific Data PMLA LP Variant

Series D, Rev. 1. Subject to technical changes.

The specified accuracies apply at an ambient temperature of 23 ± 5 °C with connected sense lines and when the devices are used with clean voltages (ripple and noise < 0.1 %). Accuracy may worsen at voltages with higher interference values. Technical data may vary for special devices/modules.
 Permissible voltages are positive or negative DC voltages.

Channels and functions	
Number of channels per device	max. 72
Number of channels per system	max. 96
Total power per device	max. 2160 W
Functions	group addressing and name assignment overcurrent protection undervoltage protection dynamic loads with list function internal measurement data memory discharge function for energy storage tests SCPI programming with measurement function MPP tracking trigger model SyncroLink for trigger synchronization saving and loading device settings watchdog in remote control mode
Operating modes	
Basic operating modes	CC, CV, CR, CP
Combined operating modes	CC+CV, CP+CV, CR+CV, CP+CC, CR+CC, CV+CC
Setting ranges	module-dependent
User interface	4.3" TFT touch display
Current rise and fall times	
With fast regulation	module-dependent
With slow regulation	ca. 1 ms
Accuracy of setting values	
Voltage	± 0.1 % of setting, ± 0.1 % of range
Current	± 0.1 % of setting ± 0.1 % of range
Resistance	± 1.4 % of setting ± 0.3 % of current range
Power (at U and I > 10 % of range)	± 0.7 % of setting
Power (at U or I 5 ... 10 % of range)	± 2 % of setting
Resolution	12 bits
Accuracy of adjustable protective devices	
Overcurrent protection	± 0.2 % of setting
Undervoltage protection	± 0.2 % of setting ± 0.2 % of range
Resolution	12 bits

Accuracy of measurement	
Voltage	±0.1 % of measured value ±0.05 % of range
Current	±0.2 % of measured value ±0.05 % of range
Resistance	is calculated from voltage and current values
Power	is calculated from voltage and current values
Resolution	16 bits
Sampling time	100 µs, not triggerable
Dynamic function (LIST)	
Operating modes	CC, CV, CR, CP
Number of load levels	max. 100, with associated ramp and dwell time
Accuracy of load levels	see accuracy of setting
Pulse duration	0.2 ms ... 1000 s
Ramp duration	0 ... 1000 s
Resolution	0.2 ms
Accuracy of the setting times	±0.02 %
SyncroLink	
Synchronism between load channels (jitter) of the same system	max. 100 µs
Synchronism between load channels (jitter) to further systems	max. 250 µs
Measurement data acquisition (DAQ) in internal memory	
Accuracy	see accuracy of measurement
Resolution	16 bits
Sampling time	0.2 ms ... 1000 s, resolution 0.2 ms
Measurement data	time stamp, voltage, current
Number of measuring points	max. 500
Settings memory	
Number of memory positions (incl. programmed list)	10, selectable
Input	
Input resistance	> 50 kΩ with load input switched off, diode function with reverse polarity up to rated current
Input capacity	module-dependent
Parallel operation	up to 5 channels in analog master-slave mode (hardware-controlled)
Maximum input voltage U _{max}	module-dependent
Minimum input voltage U _{min}	module-dependent

Input: permissible voltages	
U _{in-PE} (neg. load input - PE)	max. ±40 V DC
U _{in+PE} (pos. load input - PE)	U _{max} + 40 V DC
U _{in-in-} (neg. load inputs between the channels)	max. ±40 V DC
Power	
Continuous power	module-dependent
Derating	-1.2 %/°C for T _a > 21 °C
Protection and monitoring	
Protective devices	overcurrent, overpower, overtemperature
Monitoring messages	overvoltage indicator, polarity reversal indicator, undervoltage indicator (if input voltage is too low for set load)
Connections	
Load input	Phoenix Contact MSTB2,5/24-STF-5,08
Sense	25-pin D-sub female connector
Operating conditions	
Operating temperature	5 ... 40 °C
Storage temperature	-25 ... 65 °C
Max. operating height	2000 m above sea level
Pollution degree	2
Overvoltage category of mains	II
Max. Humidity	80 % at 31 °C, decreasing linearly to 50 % at 40 °C
Min. distance rear panel to wall or other objects	70 cm
Cooling	multi-stage air cooling, temperature-controlled, air inlet via the front panel, air outlet via the rear panel, suitable for gapless 19" mounting
Noise	max. 65 dB(A) at a distance of 1 m
Mains voltage	1/N/PE AC 100 ... 240 V 50/60 Hz
Mains cable	length max. 3 m, cross-section of mains connection wires min. 1 mm ²
Power consumption	max. 260 VA
Mechanics	
Housing	19", 3 U
Dimensions W x H x D	485 x 152 x 485 mm
Installation depth	470 mm
Installation height	134 mm
Weight	max. 22 kg
Color front panel	RAL7035 (light grey)
Color rear panel	stainless steel
Color cover	RAL7037 (stone grey)

Safety and EMC	
Protection class	1
Measurement category	0
Electrical safety	DIN EN 61010-1 DIN EN 61010-2-30
EMC, CE marking	DIN EN 61326-1 DIN EN 55011 DIN EN 61000-3-2 DIN EN 61000-3-3
Calibration	
FCC-PMLAxx	factory calibration certificate

Series-Specific Data PMLA HP Variant

Series D, Rev. 1. Subject to technical changes.

The specified accuracies apply at an ambient temperature of 23 ± 5 °C with connected sense lines and when the devices are used with clean voltages (ripple and noise < 0.1 %). Accuracy may worsen at voltages with higher interference values. Technical data may vary for special devices/modules.
 Permissible voltages are positive or negative DC voltages.

Channels and functions	
Number of channels per device	max. 1
Number of channels per system	max. 96
Total power per device	max. 2100 W
Functions	group addressing and name assignment overcurrent protection undervoltage protection dynamic loads with list function internal measurement data memory discharge function for energy storage tests SCPI programming with measurement function MPP tracking trigger model SyncroLink for trigger synchronization saving and loading device settings watchdog in remote control mode external control and monitor signals via I/O port
Operating modes	
Basic operating modes	CC, CV, CR, CP
Combined operating modes	CC+CV, CP+CV, CR+CV, CP+CC, CR+CC, CV+CC
Setting ranges	module-dependent
User interface	not available
Current rise and fall times	
at fast control speed	module-dependent
at slow control speed	ca. 1 ms
Accuracy of settings	
Voltage	± 0.1 % of setting, ± 0.1 % of range
Current	± 0.2 % of setting ± 0.1 % of range
Resistance (at 5 ... 100 % of voltage range)	± 1.4 % of setting ± 0.3 % of current range
Power (at U and I > 10 % of range)	± 0.7 % of setting
Power (at U or I > 5 ... 10 % of range)	others: ± 2 % of setting
Resolution	12 bits
Accuracy of adjustable protections	
Overcurrent protection	± 0.2 % of setting ± 0.2 % of range
Undervoltage protection	± 0.2 % of setting, ± 0.2 % of range
Resolution	12 bits

Accuracy of measurement	
Voltage	±0.1 % of measured value, ±0.05 % of range
Current	±0.2 % of measured value ±0.05 % of range
Resistance	calculated from voltage and current values
Power	calculated from voltage and current values
Resolution	16 bits
Sampling time	100 µs, not triggerable
Dynamic function (LIST)	
Operating modes	CC, CV, CR, CP
Number of load levels	max. 100, with corresponding ramp and dwell times
Accuracy of load levels	see accuracy of settings
Dwell times	0.2 ms ... 1000 s
Ramp times	0 ... 1000 s
Resolution	0.2 ms
Accuracy of time settings	±0.02 %
SyncroLink	
Synchronism between load channels (jitter) of the same system	max. 100 µs
Synchronism between load channels (jitter) to further systems	max. 250 µs
Data acquisition in internal memory	
Accuracy	see accuracy of measurement
Resolution	16 bits
Sample time	0.2 ms ... 1000 s, resolution 0.2 ms
Data points	timestamp, voltage, current
Number of data points	max. 500
Settings memory	
Number of memory positions (incl. programmed list)	10, selectable
I/O port: inputs and outputs	
Inputs	digital control input for load input analog control signal 0 ... 10 V
Digital input level	3 ... 30 V
Input resistance of analog inputs	> 10 kΩ
Outputs	analog voltage monitor output 0 ... 10 V analog current monitor output 0 ... 10 V digital status output for load input

I/O port: accuracy analog control 0 ... 10 V	
Voltage	±0.2 % of setting, ±0.1 % of range
Current	±0.2 % of setting ±0.1 % of range
I/O port: accuracy analog monitor outputs 0 ... 10 V	
Voltage	±0.1 % of analog measurement value, ±15 mV offset
Current	±0.2 % of measured value ±15 mV offset
Load capability	min. 2 kΩ
I/O port: permissible voltages	
U _{in-io} (GND - neg. load input)	max. 2 V
U _{ioPE} (GND - PE)	max. 40 V DC
Input	
Input resistance	> 50 kΩ with load input switched off, diode function with reverse polarity up to rated current
Input capacity	module-dependent
Parallel operation	up to 5 channels in analog master-slave mode (hardware-controlled)
Maximum input voltage U _{max}	module-dependent
Minimum input voltage U _{min}	module-dependent
Input: permissible voltages	
U _{in-PE} (neg. load input - PE)	max. ±40 V DC
U _{in+PE} (pos. load input - PE)	max. U _{max} + 40 V DC
U _{in-in-} (neg. load inputs between channels)	max. ±40 V DC
Power	
Continuous power	module-dependent
Derating	-1.2 %/°C for T _a > 21 °C
Protection and monitoring	
Protective devices	overcurrent, overpower, overtemperature
Monitoring messages	overvoltage indicator, polarity reversal indicator, undervoltage indicator (if input voltage is too low for set load)
Connections	
Load input	FKS20/5-SM8 (flat copper bar, vertical, 20x5 mm with M8 screw)
Sense	Phoenix Contact GIC_2,5_HCV/_2-ST-7,62

Operating conditions	
Operating temperature	5 ... 40 °C
Storage temperature	-25 ... 65 °
Max. operating height	2000 m above sea level
Pollution degree	2
Overvoltage category of mains	II
Max. humidity	80 % at 31 °C, decreasing linearly to 50 % at 40 °C
Min. distance rear panel to wall or other objects	70 cm
Cooling	multi-stage air cooling, temperature-controlled, air inlet via the front panel, air outlet via the rear panel, suitable for gapless 19" mounting
Noise	max. 65 dB(A) at distance of 1 m
Mains voltage	1/N/PE AC 100 ... 240 V 50/60 Hz
Mains cable	length max. 3 m, cross-section of mains connection wires min. 1 mm ²
Power consumption	max. 75 VA
Mechanics	
Housing	19", 2 U
Dimensions W x H x D	485 x 109 x 485 mm
Installation depth	480 mm
Installation height	89 mm
Weight	max. 16 kg
Color front panel	RAL7035 (light grey)
Color back panel	stainless steel
Color cover	RAL7037 (stone grey)
Safety and EMC	
Protection class	1
Measurement category	0
Electrical safety	DIN EN 61010-1 DIN EN 61010-2-30
EMC, CE marking	DIN EN 61326-1 DIN EN 55011 DIN EN 61000-3-2 DIN EN 61000-3-3
Calibration	
Recommended calibration interval	2 years (empirical value as a guideline for the first period of use, can be adjusted depending on the intended use, duration of use, environmental conditions, relevance of the application)
FCC-PMLAxx	factory calibration certificate
Warranty	
Warranty	2 years



Höcherl & Hackl GmbH
Industriestr. 13
94357 Konzell
GERMANY

Ph: +49 9963/94301-0
Fax: +49 9963/94301-84
office@hoecherl-hackl.com
www.hoecherl-hackl.com